



**JIM  
MACKIE** Distribution  
Company  
Supplying Quality  
Products to  
Lumber Dealers

STAIR & RAILING PRODUCTS BY



**HOUSE OF  
FORGINGS**

## Powder Coated & Stainless Steel

**House of Forgings  
is the benchmark in  
the stair and railing  
industry, offering an  
unsurpassed  
selection of quality  
products and  
expert service.**

Our vast selection of products will meet the needs of even the most discerning customers. Whether selecting a powder coated finish or stainless steel, our newels, balusters and accessories will compliment a broad range of architectural styles.

STAIR & RAILING PRODUCTS BY





Since 1993 Jim Mackie Distribution has been supplying quality millwork products to lumber dealers. We are committed to providing the best quality products at the most competitive prices. Our partnership with House of Forgings enables us to offer the preeminent and most expansive line of iron balusters on the market. Please do not hesitate to contact your Jim Mackie Distribution representative for any questions, concerns, or orders.

30881 Beverly  
Romulus, MI 48174  
Phone: (734) 729-0780  
Fax: (734) 729-0757

[www.jimmackiedistribution.com](http://www.jimmackiedistribution.com)

# Finishes & Patinas



SATIN BLACK (STB)



ASH GREY (AG)



COPPER VEIN (CV)



OIL RUBBED COPPER (ORC)



OIL RUBBED BRONZE (ORB)

House of Forgings provides an unsurpassed selection of designs in the highest quality powder coated finishes available. Our hand applied patinas enhance the lines and hammered detail of each unique piece. As interior design trends move forward, count on us to carry the latest styles & finishes.

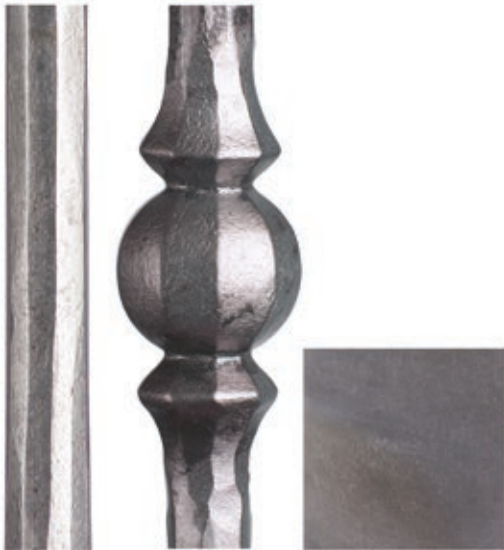

**SATIN CLEAR (SC)**

*This is a clear finish over RAW/unfinished iron, variations in surface color may occur.*



**DORADO GOLD (GD)**



**STAINLESS STEEL (Satin Polish)**



**BRASS (Satin Polish)**

*Passivated to minimize tarnishing, use gloves when handling.*



**BRUSHED CHROME (BC)**



**NICKEL (NL)**



**POLISHED BRASS (PB)**

THESE FINISHES HAVE BEEN PROFESSIONALLY PHOTOGRAPHED WITH THE HIGHEST INTEGRITY. OUR GOAL IS TO PRODUCE THE MOST REALISTIC MATCH TO THE ACTUAL FINISHES, HOWEVER SOME SLIGHT VARIANCES MAY OCCUR. All images are the sole property of House of Forgings, LLC, and cannot be copied or reproduced without written permission.

— Stainless Steel —  
Cable Railing



Red Oak 4000 Newels, 6084 Handrail with stainless round bar bracket (shown)

Create the ideal modern aesthetic by combining stainless steel cable and rich oak. The expansive views allowed for by cable make it ideal for balconies as well as staircases.

# SWAGED CABLE INFILL KITS FOR WOOD OR METAL POSTS

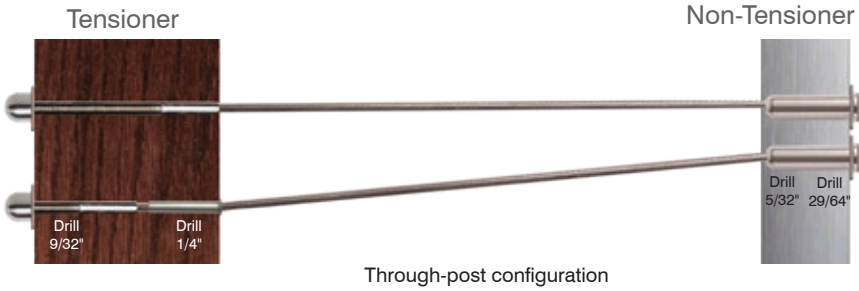

Through-post configuration

Outside to outside  
Level/balcony or angle/stair  
Steel or wood posts

|                     |     |                     |
|---------------------|-----|---------------------|
| <b>HFC18.102-5</b>  | 5'  | .15 kgs (.331 lbs)  |
| <b>HFC18.102-10</b> | 10' | .227 kgs (.5 lbs)   |
| <b>HFC18.102-15</b> | 15' | .303 kgs (.669 lbs) |
| <b>HFC18.102-20</b> | 20' | .383 kgs (.844 lbs) |

Pre-assembled kit includes fittings and factory swaged cable in lengths 5'-20'

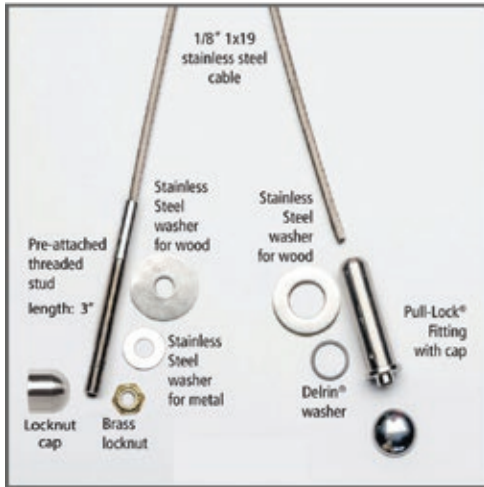

Included in kit



**MINIMUM BREAKING STRENGTH** - Cable Diameter 1/8" = 1,780 lbs.  
**1X19 STRAND TYPE 316 STAINLESS STEEL CABLE**

1 x 19 Cable - 1/8" Diameter



AISI 316

Cable Cutter



**HFC18.CUTTER**

Cable cut-off wheel



**HFC18.WHEEL**

Used to cut cable flush with the end of Pull-Lock fittings, and to cut excess threads of stud. Includes mandrel and two cut-off wheels.

Drill Kit  
Metal Post



**AX00.070.635**

Drill Kit  
Wood Post



**AX00.070.630**

Tension each row of cable equally to 225 lbs making sure not to over tighten. Use tension gauge to accurately measure tension.

**Tension Gauge**

**HFC18.TENSION.GAUGE**

**Recommended Tensioning Sequence**

## EASY AS 1-2-3

- 1. What posts are you using? Wood or metal?**
- 2. Measure your level and stair runs, calculate number of level and stair fittings.**
- 3. Add up tensioners and non-tensioners, then calculate total cable footage (plus 5%).**

### Push-Lock® Fittings

Push-Lock fittings do not require any special tools for installation. Simply push the cable into the fitting and it locks.



# SWAGELESS CABLE INFILL FOR WOOD OR METAL POSTS

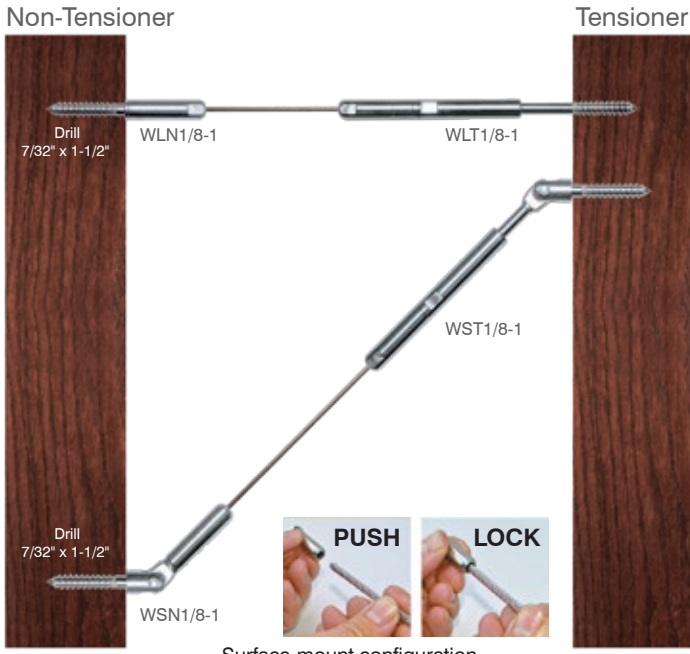

Surface-mount configuration

Inside to inside  
Level/balcony or angle/stair  
Wood posts

For use with 1/8" cable

|                  |                                   |                    |
|------------------|-----------------------------------|--------------------|
| <b>WLN1/8-1</b>  | Wood Level Non Tensioner          | .04 kgs (.092 lbs) |
| <b>WLN1/8-10</b> | Wood Level Non Tensioner(10 pack) | .31 kgs (.693 lbs) |
| <b>WLT1/8-1</b>  | Wood Level Tensioner              | .07 kgs (.173 lbs) |
| <b>WLT1/8-10</b> | Wood Level Tensioner(10 pack)     | .68 kgs (1.5lbs)   |
| <b>WSN1/8-1</b>  | Wood Stair Non Tensioner          | .06 kgs (.135 lbs) |
| <b>WSN1/8-10</b> | Wood Stair Non Tensioner(10 pack) | .5 kgs (1.12 lbs)  |
| <b>WST1/8-1</b>  | Wood Stair Tensioner              | .09 kgs (.217 lbs) |
| <b>WST1/8-10</b> | Wood Stair Tensioner(10 pack)     | .88 kgs (1.94 lbs) |

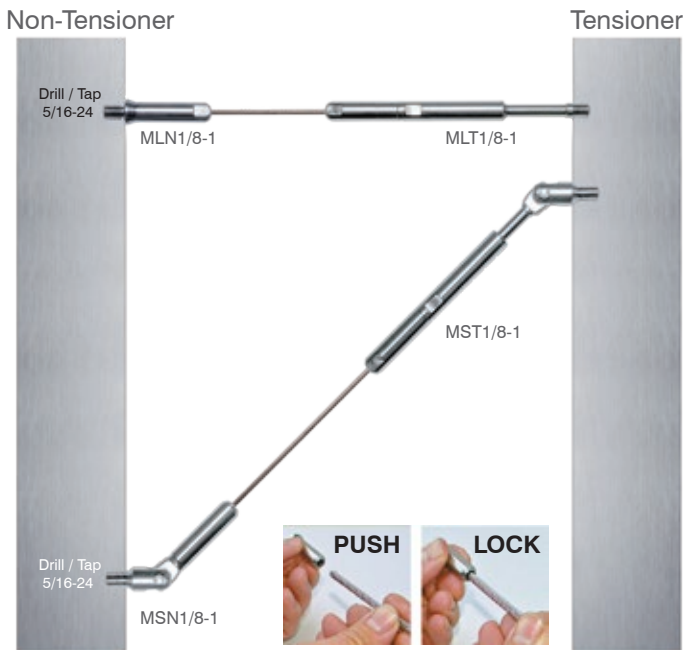

Surface-mount configuration

Inside to inside  
Level/balcony or angle/stair  
Metal posts

For use with 1/8" cable

|                  |                                    |                     |
|------------------|------------------------------------|---------------------|
| <b>MLN1/8-1</b>  | Metal Level Non Tensioner          | .04 kgs (.087 lbs)  |
| <b>MLN1/8-10</b> | Metal Level Non Tensioner(10 pack) | .29 kgs (.638lbs)   |
| <b>MLT1/8-1</b>  | Metal Level Tensioner              | .07 kgs (.158 lbs)  |
| <b>MLT1/8-10</b> | Metal Level Tensioner(10 pack)     | .61 kgs (1.349 lbs) |
| <b>MSN1/8-1</b>  | Metal Stair Non Tensioner          | .05 kgs (.118 lbs)  |
| <b>MSN1/8-10</b> | Metal Stair Non Tensioner(10 pack) | .6 kgs (1.349 lbs)  |
| <b>MST1/8-1</b>  | Metal Stair Tensioner              | .09 kgs (.202 lbs)  |
| <b>MST1/8-10</b> | Metal Stair Tensioner(10 pack)     | .81 kgs (1.793 lbs) |

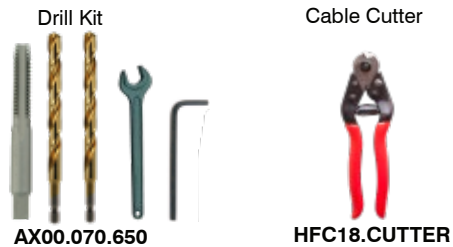

AISI 316

|                     |   |                      |
|---------------------|---|----------------------|
| <b>UTCABLE100-4</b> | 100' coil - 1/8" 1X19 type 316 S/S cable  | 2.07 kgs (4.56 lbs)  |
| <b>UTCABLE500-4</b> | 500' spool - 1/8" 1X19 type 316 S/S cable | 10.02 kgs (22.1 lbs) |

1x19 Cable(1/8" 316)

MINIMUM BREAKING STRENGTH - Cable Diameter 1/8" = 1,780 lbs.  
1X19 STRAND TYPE 316 STAINLESS STEEL CABLE





Ash Grey (shown)

SATIN BLACK  
SATIN BLACK

**HFSTB5.1.1** (.078" - 2mm)  
**HFSTB7.1.1** (.039" - 1mm)

Powder Coated Tubular Round Bar 5/8" Dia. x 8'  
Powder Coated Tubular Round Bar 5/8" Dia. x 8'

OIL RUBBED BRONZE **HFORB5.1.1**

Powder Coated Tubular Round Bar 5/8" Dia. x 8'

ASH GREY

**HFAG5.1.1**

Powder Coated Tubular Round Bar 5/8" Dia. x 8'

STAINLESS STEEL

**HFSS5.1.1**

304 Grade Stainless Steel Round Bar 5/8" Dia. x 8'  
Satin Polish Finish

Our tubular bar is made with superior 12 gauge(2 mm / 5/56") stock for minimal deflection

**HORIZONTAL**  
RAILING

Now available exclusively from House of Forgings, powder coated and stainless steel tubular round bars. These sleek 5/8" bars are available in a convenient 8' length, ideal for installation and affordable shipping. Mix and match them with our exclusive components for a look that is completely custom and uniquely you.



Ash Grey (shown)



Ash Grey (shown)



8 Satin Black (shown)



Satin Black (shown)

CURATED TRANSITIONAL STYLE

# HARMONY™ COLLECTION

AVAILABLE EXCLUSIVELY FROM HOF  
ACCEPT NO IMITATIONS

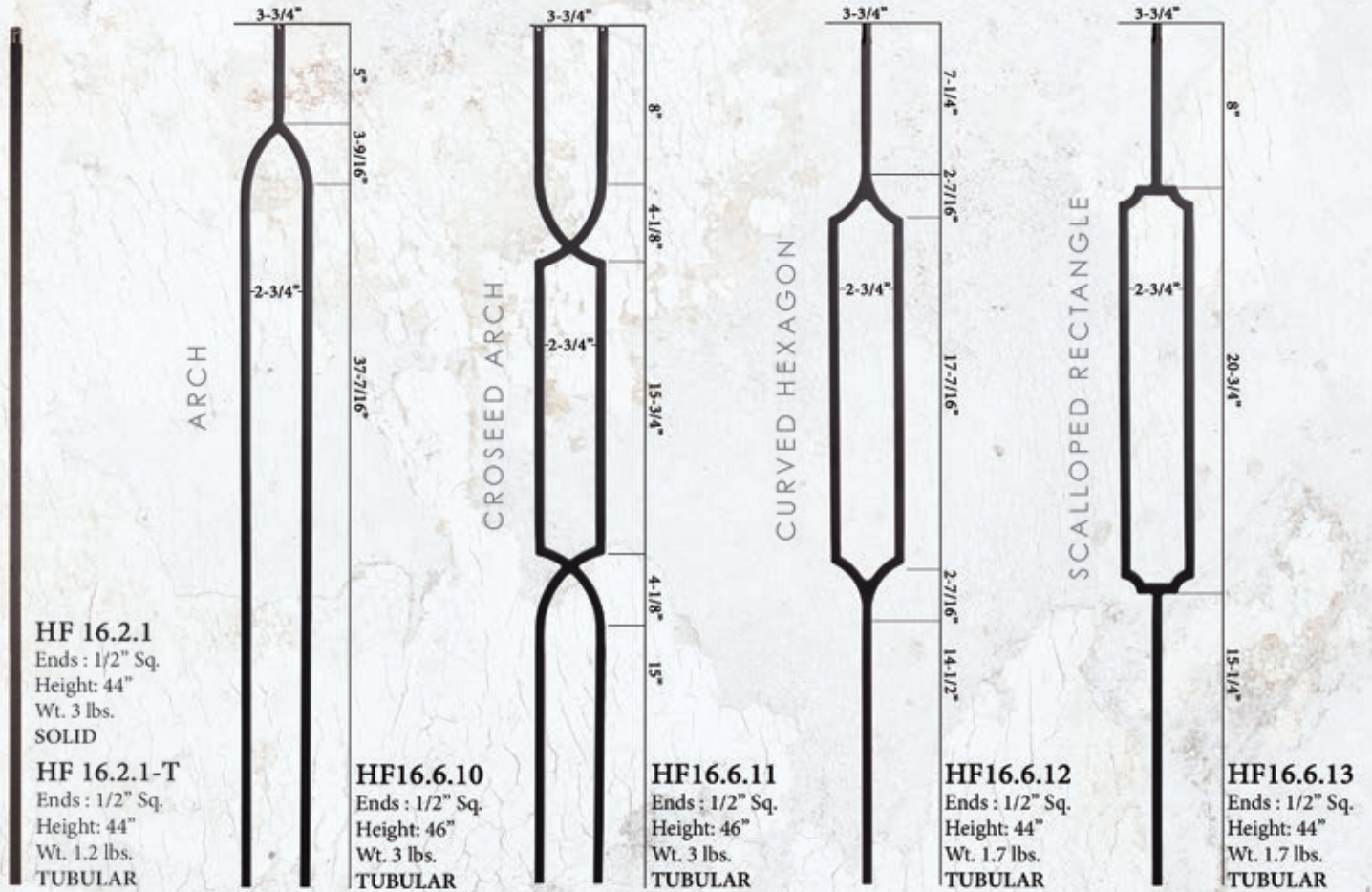

SATIN BLACK (STB)



ASH GREY (AG)

EXCLUSIVE



**HF16.3.9**  
 Level Base Collar - CAST IRON  
 Base : 1-9/16" Rd. - Height: 3/8" - Wt. .15 lbs.

**HF16.3.60**  
 Level Base Collar - ALUMINUM  
 Base : 1-9/16" Rd. - Height: 3/8" - Wt. .1 lbs.

EXCLUSIVE



**HF16.3.61** Fits angles up to 40°  
 Angled Base Collar - ALUMINUM  
 Base : 1-9/16" Rd. - Height: 3/8" - Wt. .1 lbs.



**HF16.3.19**  
 Level Base Shoe w/Set Screw - ALUMINUM  
 Base : 1-5/16" Sq. - Height: 1" - Wt. .1 lbs.



**HF16.3.2**  
 Angle Base Shoe w/Set Screw - ALUMINUM  
 Base : 1-5/16" Sq. - Height: 1-7/8" - Wt. .15 lbs.

BALUSTRADE

SOHO™

AVAILABLE EXCLUSIVELY  
FROM HOF  
ACCEPT NO IMITATIONS

ITALY·USA  
DESIGN COLLABORATIVE

PATENT PENDING

# SOHO™ | BALUSTRADE

Customize your style like never before with the latest offering from HOF. Luxurious brass and stainless steel paired with black iron makes a bold statement.

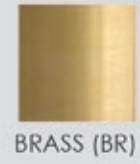

## configuration options for your style



## sleeves

## newel mounting kit flange covers

## balusters/newels

**BALUSTER** SATIN BLACK - (Powder coated)  
**BALUSTER HFSTB16.4.1** Diameter: 20mm Rd. Length: 8" Wt. .3 lbs.  
**NEWEL HFSTB16.4.3** Diameter: 35mm Rd. Length: 8" Wt. .75 lbs.

**BALUSTER** BRASS (Satin Polish - Passivated)  
**BALUSTER HF18.4.1** Diameter: 20mm Rd. Length: 8" Wt. .35 lbs.  
**NEWEL HF18.4.3** Diameter: 35 mm Rd. Length: 8" Wt. .75 lbs.

**BALUSTER** STAINLESS STEEL (Satin Polish - 304 Grade)  
**BALUSTER HF17.4.1** Diameter: 20mm Rd. Length: 8" Wt. .3 lbs.  
**NEWEL HF17.4.3** Diameter: 35mm Rd. Length: 8" Wt. .75 lbs.

Fits 1-3/16" Round Newels  
 Diameter: 4.13" Height: .7"



SATIN BLACK  
**HFSTB16.4.5**  
 Also available in Ash Grey.  
 See page 62.



BRASS  
**HF18.4.5**



STAINLESS STEEL  
**HF17.4.5**

**NEWEL MOUNTING KIT**  
 Fits 1-3/16" Round Newels  
**HF16.2.9**



Replacement set screws  
 Satin Black, Brass, Stainless Steel

**BALUSTER** SATIN BLACK - (Powder coated)  
**BALUSTER HFSTB16.8.1** Diameter: 5/8" Rd. Tubular Length: 44" Wt. 1.35 lbs.  
**NEWEL HFSTB16.5.11-T** Diameter: 1-3/16" Rd. Tubular Length: 47" Wt. 4.8 lbs.

**BALUSTER** BRASS (Satin Polish - Passivated)  
**BALUSTER HF18.8.1** Diameter: 5/8" Rd. Tubular Length: 44" Wt. 1.45 lbs.  
**NEWEL HF18.8.3** Diameter: 1-3/16" Rd. Tubular Length: 47" Wt. 5.7 lbs.

**BALUSTER** STAINLESS STEEL (Satin Polish - 304 Grade)  
**BALUSTER HF17.8.1** Diameter: 5/8" Rd. Tubular Length: 44" Wt. 1.2 lbs.  
**NEWEL HF17.1.2-T** Diameter: 1-3/16" Rd. Tubular Length: 47" Wt. 5.7 lbs.



AVAILABLE  
EXCLUSIVELY  
FROM HOF

ACCEPT  
NO IMITATIONS

Photo courtesy of Homes by Sal Cohen - Bellevue, WA

Satin Black (shown)

**ITALY · USA**  
DESIGN COLLABORATIVE

PATENT PENDING

# FOUNDATION™

BALUSTERS

- TUBULAR
- NO COLLARS OR SHOES REQUIRED
- AFFORDABLE STYLE

**SATIN BLACK**

**HFSTB16.7.5**

1" Square (Tubular)

Weight: 1.15 lbs.  
1/2" Square (Tubular)



**ASH GREY**

**HFAG16.7.5**



**OIL RUBBED BRONZE**

**HFORB16.7.5**



Bottom pin for quick installation!



Ash Grey (shown)



Photo courtesy of Home Lumber  
New Haven, IN

Satin Black (shown)



Satin Black (shown)

# MEGA SQUARE



## Finishes & Patinas



SATIN BLACK (STB)



ASH GREY (AG)











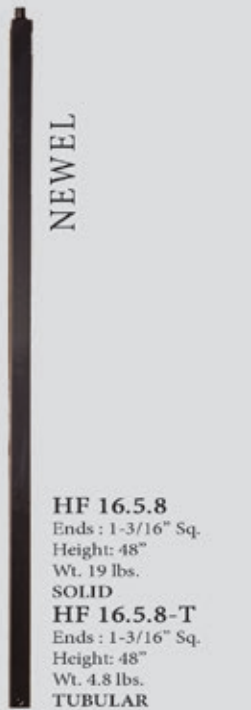

OIL RUBBED BRONZE (ORB)



**Pintop**  
Diameter : 5/8"  
Height: 3/4"

**Tubular Bar Specifications**  
Superior 18 gauge wall thickness  
(1/20" / 1.27mm)

|   |  |  |  |  |   |  |
|---|--|--|--|--|---|--|
|  <p style="writing-mode: vertical-rl; transform: rotate(180deg);"><b>NEWEL</b></p> <p><b>HF 16.5.8</b><br/>Ends : 1-3/16" Sq.<br/>Height: 48"<br/>Wt. 19 lbs.<br/><b>SOLID</b></p> <p><b>HF 16.5.8-T</b><br/>Ends : 1-3/16" Sq.<br/>Height: 48"<br/>Wt. 4.8 lbs.<br/><b>TUBULAR</b></p> |  <p><b>HF 34.2.1-T</b><br/>Ends : 3/4" Sq.<br/>Height: 44"<br/>Wt. 1.5 lbs.<br/><b>TUBULAR</b></p> |  <p><b>HF 34.1.1-T</b><br/>Ends : 3/4" Sq.<br/>Height: 44"<br/>Wt. 1.5 lbs.<br/><b>TUBULAR</b></p> |  <p><b>HF 34.1.2-T</b><br/>Ends : 3/4" Sq.<br/>Height: 44"<br/>Wt. 1.5 lbs.<br/><b>TUBULAR</b></p> |  <p><b>HF 34.1.3-T</b><br/>Ends : 3/4" Sq.<br/>Height: 44"<br/>Wt. 2.45 lbs.<br/><b>TUBULAR</b></p> |  <p><b>HF 34.1.4-T</b><br/>Ends : 3/4" Sq.<br/>Height: 44"<br/>Wt. 3.35 lbs.<br/><b>TUBULAR</b></p> |  <p><b>HF 34.1.25-T</b><br/>Ends : 3/4" Sq.<br/>Height: 44"<br/>Wt. 5.05 lbs.<br/><b>TUBULAR</b></p> |
|---|--|--|--|--|---|--|

|   |  |   |   |
|---|--|---|---|
|  <p><b>HF 34.1.34-T</b><br/>Ends : 3/4" Sq.<br/>Height: 44"<br/>Wt. 1.75 lbs.<br/><b>TUBULAR</b></p> |  <p><b>HF 34.1.35-T</b><br/>Ends : 3/4" Sq.<br/>Height: 44"<br/>Wt. 2 lbs.<br/><b>TUBULAR</b></p> | <p style="text-align: center;">EXCLUSIVE</p>  <p><b>HF 34.6.1</b><br/>Ends : 3/4" Sq.<br/>Height: 44"<br/>Wt. 3.25 lbs.<br/><b>TUBULAR</b></p> | <p style="text-align: center;">EXCLUSIVE</p>  <p><b>HF 34.6.3</b><br/>Ends : 3/4" Sq.<br/>Height: 44"<br/>Wt. 2.35 lbs.<br/><b>TUBULAR</b></p> |
|---|--|---|---|

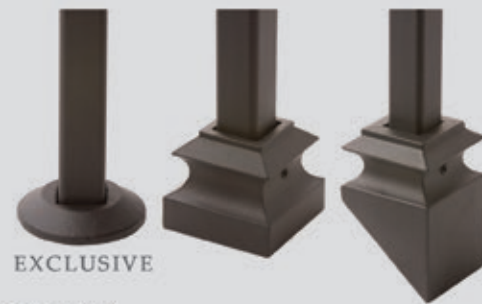

EXCLUSIVE

**HF34.3.16**  
Level Base Collar - CAST IRON  
Base : 2" Rd. - Height: 3/8" - Wt. .15 lbs.

**HF34.3.19**  
Level Base Shoe w/Set Screw - ALUMINUM  
Base : 1-7/8" Sq. - Height: 1-9/16" - Wt. .1 lbs.

**HF34.3.2**  
Angle Base Shoe w/Set Screw - ALUMINUM  
Base : 1-7/8" Sq. - Height: 2-7/8" - Wt. .15 lbs.

**HF16.2.3**  
Newel Mounting Kit

For photos and full accessory details see page 36





# WENTWORTH

ROUND HAND FORGED    SQUARE RUSTIC HAMMERED



## Finishes & Patinas

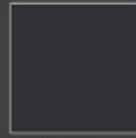

SATIN BLACK  
(STB)



OIL RUBBED  
BRONZE  
(ORB)



SATIN CLEAR  
(SC)

### ACCESSORIES

Round level base shoes                    **HF16.3.35**  
 Round angled base shoes                **HF16.3.36**  
 Round level base collar(modern)       **HF16.3.12**

Photos: J.  
 Photos: N.  
 Photos: Q.

Square level base shoes                    **HF16.3.38**  
 Square angled base shoes                **HF16.3.39**  
 Square level base collar(modern)       **HF16.3.15**

Photos: C.  
 Photos: G.  
 Photos: P.

Round newel mounting kit                 **HF16.3.33**  
 Square newel mounting kit                **HF16.3.31**

Photos: U.  
 Photos: T.

For photos and full accessory details see page 36



|  |  |  |  |   |   |
|--|--|--|--|---|---|
| <p style="text-align: center;"><b>NEWEL</b></p> <p style="text-align: center;">47"</p> <p><b>HF 1.1.22</b><br/>                 Ends : 1" Rd.<br/>                 Height: 47"<br/>                 Wt. 18 lbs.<br/>                 SOLID</p> | <p style="text-align: center;">44"</p> <p><b>HF 3.1.1</b><br/>                 Ends : 5/8" Rd.<br/>                 Height: 44"<br/>                 Wt. 3.6 lbs.<br/>                 SOLID</p> | <p style="text-align: right;">9-1/2"</p> <p style="text-align: right;">2"</p> <p style="text-align: right;">7"</p> <p style="text-align: right;">2"</p> <p style="text-align: right;">7"</p> <p style="text-align: right;">2"</p> <p style="text-align: right;">14-1/2"</p> <p><b>HF 3.1.2</b><br/>                 Ends : 5/8" Rd.<br/>                 Height: 44"<br/>                 Wt. 3.58 lbs.<br/>                 SOLID</p> | <p style="text-align: center;"><b>NEWEL</b></p> <p style="text-align: center;">47"</p> <p><b>HF 1.1.23</b><br/>                 Ends : 1" Sq.<br/>                 Height: 47"<br/>                 Wt. 18 lbs.<br/>                 SOLID</p> | <p style="text-align: center;">44"</p> <p><b>HF 3.2.1</b><br/>                 Ends : 5/8" Sq.<br/>                 Height: 44"<br/>                 Wt. 4.28 lbs.<br/>                 SOLID</p> | <p style="text-align: right;">9-1/2"</p> <p style="text-align: right;">1-1/2"</p> <p style="text-align: right;">7-3/4"</p> <p style="text-align: right;">1-1/2"</p> <p style="text-align: right;">7-3/4"</p> <p style="text-align: right;">1-1/2"</p> <p style="text-align: right;">14-1/2"</p> <p><b>HF 3.2.2</b><br/>                 Ends : 5/8" Sq.<br/>                 Height: 44"<br/>                 Wt. 5.2 lbs.<br/>                 SOLID</p> |
|--|--|--|--|---|---|

Hand forged product, variance in specifications may occur.

# AALTO

SQUARE



## Finishes & Patinas

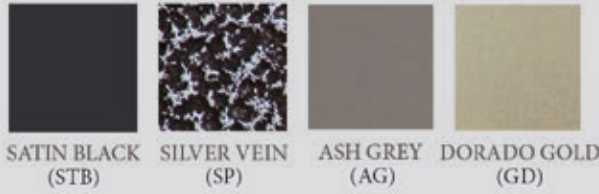

SATIN BLACK (STB) SILVER VEIN (SP) ASH GREY (AG) DORADO GOLD (GD)

|     | NEWELS | HF16.5.8 | HF16.5.8-T | BALUSTERS | HF16.2.1 | HF16.2.1-T | HF16.2.1-50 | HF16.1.30 | HF16.1.30-T | HF16.1.31 | HF16.1.31-T | HF16.1.32 | HF16.1.32-T | HF16.6.1 | HF16.6.2 | HF16.6.3 | HF16.6.4 | HF16.6.5 | HF16.6.7 | HF16.6.8 | HF16.6.9 | HF9.4.11 |   |
|-----|--------|----------|------------|-----------|----------|------------|-------------|-----------|-------------|-----------|-------------|-----------|-------------|----------|----------|----------|----------|----------|----------|----------|----------|----------|---|
| STB |        | •        |            |           | •        | •          | •           | •         |             | •         |             | •         |             | •        | •        | •        | •        | •        | •        | •        | •        | •        | • |
| SP  |        | •        |            |           | •        | •          |             |           |             |           |             |           |             |          |          |          |          |          |          |          |          |          |   |
| AG  |        |          | •          |           |          | •          |             |           | •           |           | •           |           | •           | •        | •        | •        | •        | •        | •        | •        | •        | •        | • |
| GD  |        | •        |            |           | •        |            |             |           |             |           |             |           |             | •        |          | •        |          |          |          | •        |          |          |   |

### ACCESSORIES

- Level base shoes **HF16.3.1, HF16.3.19**
- Level base collars **HF16.3.4, HF16.3.5,**
- Angled base shoes **HF16.3.2, HF16.3.30**
- Adjustable level base shoes **HF16.3.44, HF16.3.46**
- Adjustable angle base shoes **HF16.3.45, HF16.3.47**
- Level base collars(modern) **HF16.3.9, HF16.3.60**
- Angled base collars(modern) **HF16.3.61**
- Newel mounting kit **HF16.2.3**

- Photos: A. A.
- Photos: D. H.
- Photos: E. G.
- Photos: R.
- Photos: S.
- Photos: P. O2 **NEW**
- Photos: O3 **NEW**
- Photos: T.



For photos and full accessory details see page 36



Satin Black (shown)



**HF 16.5.8**  
Ends : 1-3/16" Sq.  
Height: 48"  
Wt. 19 lbs.  
SOLID

**HF 16.5.8-T**  
Ends : 1-3/16" Sq.  
Height: 48"  
Wt. 4.8 lbs.  
TUBULAR



**HF 16.2.1**  
Ends : 1/2" Sq.  
Height: 44"  
Wt. 3 lbs.  
SOLID

**HF 16.2.1-T**  
Ends : 1/2" Sq.  
Height: 44"  
Wt. 1.2 lbs.  
TUBULAR

**HF 16.2.1-50**  
Ends : 1/2" Sq.  
Height: 50"  
Wt. 3.2 lbs.  
SOLID



**HF 16.1.30**  
Ends : 1/2" Sq.  
Height: 44"  
Wt. 3.4 lbs.  
SOLID

**HF 16.1.30-T**  
Ends : 1/2" Sq.  
Height: 44"  
Wt. 1.6 lbs.  
TUBULAR



**HF 16.1.31**  
Ends : 1/2" Sq.  
Height: 44"  
Wt. 3.6 lbs.  
SOLID

**HF 16.1.31-T**  
Ends : 1/2" Sq.  
Height: 44"  
Wt. 1.75 lbs.  
TUBULAR



**HF 16.1.32**  
Ends : 1/2" Sq.  
Height: 44"  
Wt. 10 lbs.  
SOLID

**HF 16.1.32-T**  
Ends : 1/2" Sq.  
Height: 44"  
Wt. 5 lbs.  
TUBULAR



**HF 16.6.1**  
Ends : 1/2" Sq.  
Height: 44"  
Wt. 2.5 lbs.  
TUBULAR



**HF 16.6.8**  
Ends : 1/2" Sq.  
Height: 44"  
Wt. 1.75 lbs.  
TUBULAR



**HF 16.6.9**  
Ends : 1/2" Sq.  
Height: 44"  
Wt. 1.6 lbs.  
TUBULAR



**HF 16.6.7**  
Ends : 1/2" Sq.  
Height: 44"  
Wt. 1.6 lbs.  
TUBULAR



**HF 16.6.2**  
Ends : 1/2" Sq.  
Height: 44"  
Wt. 1.6 lbs.  
TUBULAR



**HF 16.6.3**  
Ends : 1/2" Sq.  
Height: 44"  
Wt. 1.7 lbs.  
TUBULAR



**HF 16.6.4**  
Ends : 1/2" Sq.  
Height: 44"  
Wt. 1.7 lbs.  
TUBULAR



**HF 16.6.5**  
Ends : 1/2" Sq.  
Height: 44"  
Wt. 1.8 lbs.  
TUBULAR

fits all angles up to 40 degrees



**HF 9.4.11**  
Ends : 1/2" Sq.  
Height: 46"  
Wt. 4.5 lbs.  
TUBULAR (Rake)

# TUSCAN

ROUND HAND FORGED



## Finishes & Patinas

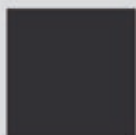

SATIN BLACK (STB)

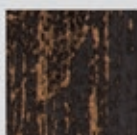

OIL RUBBED BRONZE (ORB)



SATIN CLEAR (SC)

|     | NEWELS | HF1.1.22 | HF1.1.9 | HF1.1.21 | BALUSTERS | HF2.9.21 | HF2.1.5 | HF2.1.6 | HF2.1.7 | HF2.1.9 | HF2.1.8 | HF2.1.11 | HF2.6.8 | HF2.6.9 | HF2.6.7 | HF2.10.2 | HF2.10.4 | HF2.10.3 |
|-----|--------|----------|---------|----------|-----------|----------|---------|---------|---------|---------|---------|----------|---------|---------|---------|----------|----------|----------|
| STB |        | •        | •       | •        |           | •        | •       | •       | •       | •       | •       | •        | •       | •       | •       | •        | •        | •        |
| ORB |        |          |         |          |           | •        | •       | •       | •       | •       | •       | •        | •       | •       | •       | •        | •        | •        |
| SC  |        | •        |         | •        |           | •        |         |         |         |         |         |          | •       | •       | •       | •        | •        | •        |

### ACCESSORIES

- Level base shoes
- Level base collars
- Angled base shoes
- Adjustable level base shoes
- Adjustable angle base shoes
- Level base collars(modern)

- HF16.3.26
- HF16.3.40, HF16.3.43
- HF16.3.27
- HF16.3.44, HF16.3.46
- HF16.3.45, HF16.3.47
- HF16.3.10

- Photos: J.
- Photos: K. O.
- Photos: N.
- Photos: R.
- Photos: S.
- Photos: Q. **NEW**

For photos and full accessory details see page 36



**HF 1.1.22**  
Ends: 1" Rd.  
Height: 47-1/4"  
Wt. 18 lbs.



**HF 1.1.9**  
Ends: 1" Rd.  
Height: 47-1/4"  
Wt. 18 lbs.



**HF 1.1.21**  
Ends: 1" Rd.  
Tapered  
Height: 47-1/4"  
Wt. 18 lbs.



**HF 2.1.5**  
Ends: 9/16" Rd.  
Height: 44"  
Wt. 2.5 lbs.



**HF 2.1.6**  
Ends: 9/16" Rd.  
Height: 44"  
Wt. 4.2 lbs.



**HF 2.1.7**  
Ends: 9/16" Rd.  
Height: 44"  
Wt. 3 lbs.



**HF 2.1.9**  
 Ends : 9/16" Rd.  
 Height: 44"  
 Wt. 2.4 lbs.



**HF 2.1.8**  
 Ends : 9/16" Rd.  
 Height: 44"  
 Wt. 4.2 lbs.



**HF 2.1.11**  
 Ends : 9/16" Rd.  
 Height: 44"  
 Wt. 3 lbs.



**HF 2.6.8**  
 Ends : 9/16" Rd.  
 Tapered  
 Height: 44"  
 Wt. 3.2 lbs.



**HF 2.6.9**  
 Ends : 9/16" Rd.  
 Height: 44"  
 Wt. 4.2 lbs.



**HF 2.6.7**  
 Ends : 9/16" Rd.  
 Tapered  
 Height: 44"  
 Wt. 3.8 lbs.



**HF 2.9.21**  
 Ends : 9/16" Rd.  
 Height: 44"  
 Wt. 2.4 lbs.



**HF 2.10.2**  
 Ends : 9/16" Rd.  
 Height: 44"  
 Wt. 3.2 lbs.



**HF 2.10.4**  
 Ends : 9/16" Rd.  
 Height: 44"  
 Wt. 4.2 lbs.



**HF 2.10.3**  
 Ends : 9/16" Rd.  
 Height: 44"  
 Wt. 3.6 lbs.



## Finishes & Patinas



SATIN BLACK  
(STB)



OIL RUBBED  
BRONZE  
(ORB)

|     | NEWELS | HF1.1.14-T | BALUSTERS | HF2.9.12 | HF2.9.11 | HF2.9.13 | HF2.9.3 | HF2.9.4 | HF2.9.8 | HF2.9.5 | HF2.9.6 | HF2.1.2 | HF2.1.1 | HF2.9.20 | HF2.9.20-T | HF2.9.28 | HF2.9.28-T | HF2.9.27 | HF2.9.26 | HF2.9.26-T | HF2.9.29 | HF2.9.36 | HF2.9.37 |
|-----|--------|------------|-----------|----------|----------|----------|---------|---------|---------|---------|---------|---------|---------|----------|------------|----------|------------|----------|----------|------------|----------|----------|----------|
| STB |        | •          |           | •        | •        | •        | •       | •       | •       | •       | •       | •       | •       | •        | •          | •        | •          | •        | •        | •          | •        | •        | •        |
| ORB |        |            |           | •        | •        | •        | •       | •       | •       | •       | •       | •       | •       | •        | •          | •        | •          | •        | •        | •          | •        | •        | •        |

### ACCESSORIES

Level base shoes

Level base collars

Angled base shoes

Adjustable level base shoes

Adjustable angle base shoes

Level base collars(modern)

Newel mounting kit

HF16.3.25

HF16.3.41, HF16.3.42

HF16.3.28

HF16.3.44, HF16.3.46

HF16.3.45, HF16.3.47

HF16.3.11

HF16.3.31

Photos: C.

Photos: D. H.

Photos: G.

Photos: R.

Photos: S.

Photos: P. **NEW**

Photos: T.

For photos and full accessory details see page 36



NEWEL

47-1/4"

HF 1.1.14-T

Ends : 1" Sq.  
Height: 47-1/4"  
Wt. 2.30 lbs.  
TUBULAR



HF 2.9.20

Ends : 9/16" Sq.  
Height: 44"  
Wt. 3 lbs.

SOLID

HF 2.9.20-T

Ends : 9/16" Sq.  
Height: 44"  
Wt. 1.05 lbs.  
TUBULAR



HF 2.9.12

Ends : 9/16" Sq.  
Tapered  
Height: 44"  
Wt. 3.8 lbs.



HF 2.9.11

Ends : 9/16" Sq.  
Height: 44"  
Wt. 5 lbs.



HF 2.9.13

Ends : 9/16" Sq.  
Tapered  
Height: 44"  
Wt. 5.5 lbs.

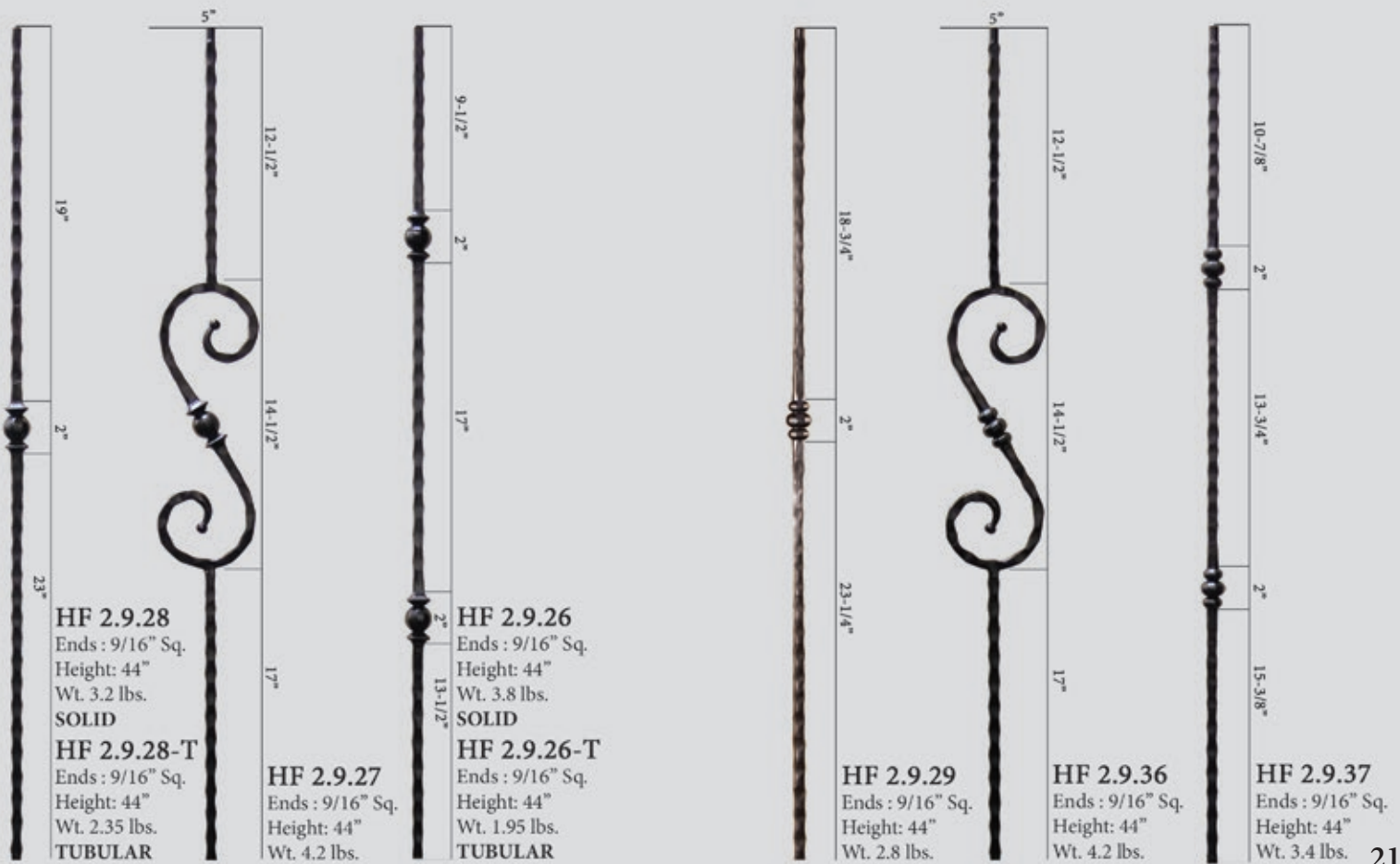

# MONTE CARLO

ROUND



## Finishes & Patinas



\*Middle section is hollow cast iron,  
ends are hollow cast steel



\*Middle section is hollow cast aluminum, ends are hollow cast steel



### ACCESSORIES

- Level base shoes
- Angled base shoes
- Level base collars(modern)
- Newel mounting kit

- HF16.3.50**
- HF16.3.51**
- HF16.3.12**
- HF16.3.14**

- Photos: I.
- Photos: M.
- Photos: Q. **NEW**
- Photos: U.

For photos and full accessory details see page 36





# DESIGNER TUBULAR

SQUARE



## Finishes & Patinas



SATIN BLACK  
(STB)



OIL RUBBED  
BRONZE  
(ORB)



**HF 16.8.6**  
Ends : 5/8" Sq.  
Height: 44"  
Wt. 2 lbs.  
TUBULAR



**HF 16.8.10**  
Ends : 5/8" Sq.  
Height: 44"  
Wt. 2 lbs.  
TUBULAR



**HF 16.8.11**  
Ends : 5/8" Sq.  
Height: 44"  
Wt. 2 lbs.  
TUBULAR



**HF 16.8.8**  
Ends : 5/8" Sq.  
Height: 44"  
Wt. 3 lbs.  
TUBULAR



**HF 16.8.9**  
Ends : 5/8" Sq.  
Height: 44"  
Wt. 4 lbs.  
TUBULAR

## ACCESSORIES

- Level base shoes
- Angled base shoes
- Level base collars(modern)

**HF16.3.38**  
**HF16.3.39**  
**HF16.3.15**

Photos: J. C.  
Photos: N. G.  
Photos: P. **NEW**

For photos and full accessory details see page 36



# STAINLESS STEEL



Stainless steel is a mainstay in the modern and contemporary home decor market. The simple, honest lines of this profile is the perfect compliment to your urban dwelling. Now, offered in a more affordable tubular style for the budget savvy buyer.

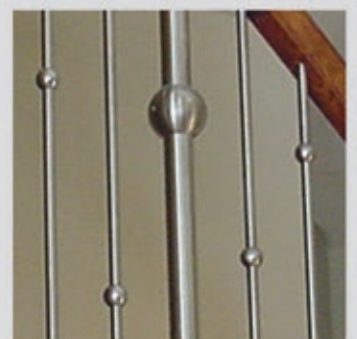

# STAINLESS STEEL



NEWEL

**HF17.1.2**  
Ends : 1-3/16" Rd.  
Height: 47"  
Wt. 18 lbs.  
**SOLID**

**HF17.1.2-T**  
Ends : 1-3/16" Rd.  
Height: 47"  
Wt. 5.7 lbs.  
**TUBULAR**



NEWEL

**HF17.12.1-T**  
Ends : 1-3/16" Rd.  
Height: 47"  
Wt. 5.7 lbs.  
**TUBULAR**



**HF17.11.5**  
Ends : 9/16" Rd.  
Height: 44"  
Wt. 3.5 lbs.  
**SOLID**

**HF17.11.5-T**  
Ends : 9/16" Rd.  
Height: 44"  
Wt. 1.25 lbs.  
**TUBULAR**



**HF17.11.21-T**  
Ends : 9/16" Rd.  
Height: 44"  
Wt. 1.25 lbs.  
**TUBULAR**



**HF17.11.23-T**  
Ends : 9/16" Rd.  
Height: 44"  
Wt. 1.25 lbs.  
**TUBULAR**

## ACCESSORIES

Level base collar  
Newel mounting kit

**HF17.11.22**  
**HF17.2.3**

Photos: L.  
Photos: V.

For photos and full accessory details see page 36



# GOTHIC

SQUARE FACE HAMMERED



## Finishes & Patinas



SATIN BLACK  
(STB)



OIL RUBBED  
BRONZE  
(ORB)

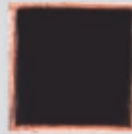

OIL RUBBED  
COPPER  
(ORC)



NEWEL

STB  
(ONLY)

**HF 16.5.6**  
Ends : 1-3/16" Sq.  
Height: 48"  
Wt. 22 lbs.



**HF 16.1.7**  
Ends : 9/16" Sq.  
Height: 44"  
Wt. 4 lbs.  
**SOLID**



**HF 16.5.2**  
Ends : 9/16" Sq.  
Height: 44"  
Wt. 3.5 lbs.  
**SOLID**



**HF 16.1.8**  
Ends : 9/16" Sq.  
Height: 44"  
Wt. 3.8 lbs.  
**SOLID**



**HF 16.1.9**  
Ends : 9/16" Sq.  
Height: 44"  
Wt. 4.5 lbs.  
**SOLID**

## ACCESSORIES

- Level base shoes
- Level base collars
- Angled base shoes
- Adjustable level base shoes
- Adjustable angle base shoes
- Level base collars(modern)
- Newel mounting kit

- HF16.3.3, HF16.3.20, HF16.3.25**
- HF16.3.41, HF16.3.42**
- HF16.3.17, HF16.3.28**
- HF16.3.44, HF16.3.46**
- HF16.3.45, HF16.3.47**
- HF16.3.11**
- HF16.2.3**

- Photos: A. A. C.
- Photos: D. H.
- Photos: E. G.
- Photos: R.
- Photos: S.
- Photos: P. **NEW**
- Photos: T.

For photos and full accessory details see page 36





# ROUND ROUND SMOOTH



## Finishes & Patinas



SATIN BLACK  
(STB)



OIL RUBBED  
BRONZE  
(ORB)



ASH GREY  
(AG)

|     | NEWELS | HF16.5.11 | HF16.5.11-T | HF1.1.19 | BALUSTERS | HF16.2.2 | HF16.1.17 | HF16.1.18 | HF16.1.19 | HF16.1.20 | HF16.1.25-R | HF2.11.3 | HF2.11.3-T | HF2.11.4 | HF2.11.4-T | HF2.11.16 | HF2.11.16-T | HF16.8.1 | HF16.8.12 | HF16.8.13 |   |
|-----|--------|-----------|-------------|----------|-----------|----------|-----------|-----------|-----------|-----------|-------------|----------|------------|----------|------------|-----------|-------------|----------|-----------|-----------|---|
| STB |        | •         |             | •        |           | •        | •         | •         | •         | •         | •           | •        | •          | •        | •          | •         | •           | •        | •         | •         | • |
| ORB |        |           |             |          |           |          |           |           |           |           |             |          | •          |          | •          |           | •           |          |           |           |   |
| AG  |        |           | •           |          |           |          |           |           |           |           |             |          |            |          |            |           |             |          |           |           |   |



NEWEL

**HF 16.5.11**  
Ends : 1-3/16" Rd.  
Height: 48"  
Wt. 19 lbs.  
SOLID

**HF 16.5.11-T**  
Ends : 1-3/16" Rd.  
Height: 48"  
Wt. 5.7 lbs.  
TUBULAR



**HF 16.2.2**  
Ends : 9/16" Rd.  
Height: 44"  
Wt. 2.7 lbs.



**HF 16.1.17**  
Ends : 9/16" Rd.  
Height: 44"  
Wt. 2.7 lbs.



**HF 16.1.18**  
Ends : 9/16" Rd.  
Height: 44"  
Wt. 3 lbs.



**HF 16.1.19**  
Ends : 9/16" Rd.  
Height: 44"  
Wt. 4 lbs.



**HF 16.1.20**  
Ends : 9/16" Rd.  
Height: 44"  
Wt. 5 lbs.



**ACCESSORIES**

- Level base shoes
- Level base collars
- Angled base shoes
- Adjustable level base shoes
- Adjustable angle base shoes
- Level base shoe, fits 5/8"
- Angled base shoe, fits 5/8"
- Level base collars(modern)
- Newel mounting kit

- HF16.3.13, HF16.3.26**
- HF16.3.40, HF16.3.43**
- HF16.3.16, HF16.3.27**
- HF16.3.44, HF16.3.46**
- HF16.3.45, HF16.3.47**
- HF16.3.35**
- HF16.3.36**
- HF16.3.10, HF16.3.12**
- HF16.3.14, HF16.3.33, HF16.2.9**

- Photos: L. J.
- Photos: K. O.
- Photos: M. N.
- Photos: R.
- Photos: S.
- Photos: J.
- Photos: N.
- Photos: Q. **NEW**
- Photos: U.

For photos and full accessory details see page 36 

# VERSATILE SQUARE



## Finishes & Patinas

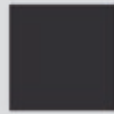

SATIN BLACK  
(STB)



COPPER VEIN  
(CV)



OIL RUBBED  
BRONZE  
(ORB)



OIL RUBBED  
COPPER  
(ORC)

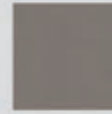

ASH GREY  
(AG)

|     | NEWELS | HF16.5.8 | HF16.5.8-T | HF16.5.9 | BALUSTERS | HF16.2.1 | HF16.2.1-T | HF16.2.1-50 | HF16.1.34 | HF16.1.34-T | HF16.1.35 | HF16.1.35-T | HF16.1.45 | HF16.1.45-T | HF2.10.1 | HF2.2.3 | HF16.1.25 | HF16.1.25-T | HF16.1.25-S |   |
|-----|--------|----------|------------|----------|-----------|----------|------------|-------------|-----------|-------------|-----------|-------------|-----------|-------------|----------|---------|-----------|-------------|-------------|---|
| STB |        | •        |            | •        |           | •        | •          | •           | •         | •           | •         | •           | •         | •           | •        | •       | •         | •           | •           | • |
| AG  |        |          | •          |          |           |          | •          |             |           | •           |           | •           |           |             |          |         |           |             | •           |   |
| CV  |        |          |            |          |           | •        | •          |             |           | •           |           | •           |           |             |          |         | •         | •           |             |   |
| ORB |        | •        |            |          |           | •        | •          |             | •         | •           | •         | •           |           |             | •        | •       | •         | •           | •           | • |
| ORC |        | •        |            |          |           | •        | •          |             | •         | •           | •         | •           |           |             | •        |         | •         | •           | •           | • |

**NEWEL**

**HF 16.5.8**  
Ends : 1-3/16" Sq.  
Height: 48"  
Wt. 19 lbs.  
SOLID

**HF 16.5.8-T**  
Ends : 1-3/16" Sq.  
Height: 48"  
Wt. 4.8 lbs.  
TUBULAR

**NEWEL**

**HF 16.5.9**  
Ends : 1-3/16" Sq.  
Height: 48"  
Wt. 20 lbs.  
SOLID

**HF 16.2.1**  
Ends : 1/2" Sq.  
Height: 44"  
Wt. 3 lbs.  
SOLID

**HF 16.2.1-T**  
Ends : 1/2" Sq.  
Height: 44"  
Wt. 1.2 lbs.  
TUBULAR

**HF 16.2.1-50**  
Ends : 1/2" Sq.  
Height: 50"  
Wt. 3.2 lbs.  
SOLID

**HF 16.1.34**  
Ends : 1/2" Sq.  
Height: 44"  
Wt. 4 lbs.  
SOLID

**HF 16.1.34-T**  
Ends : 1/2" Sq.  
Height: 44"  
Wt. 1.35 lbs.  
TUBULAR

**HF 16.1.35**  
Ends : 1/2" Sq.  
Height: 44"  
Wt. 3.5 lbs.  
SOLID

**HF 16.1.35-T**  
Ends : 1/2" Sq.  
Height: 44"  
Wt. 1.5 lbs.  
TUBULAR

**HF 16.1.45**  
Ends : 1/2" Sq.  
Height: 44"  
Wt. 4 lbs.  
SOLID

**HF 16.1.45-T**  
Ends : 1/2" Sq.  
Height: 44"  
Wt. 1.55 lbs.  
TUBULAR





**HF 2.10.1**  
 Ends : 1/2" Sq.  
 Height: 44"  
 Wt. 4.2 lbs.



**HF 2.2.3**  
 Ends : 1/2" Sq.  
 Height: 44"  
 Wt. 3 lbs.



**HF 16.1.25**  
 Ends : 1/2" Sq.  
 Height: 44"  
 Wt. 5.2 lbs.  
**SOLID**

**HF 16.1.25-T**  
 Ends : 1/2" Sq.  
 Height: 44"  
 Wt. 3.85 lbs.  
**TUBULAR**



**HF 16.1.25-S**  
 Ends : 1/2" Sq.  
 Height: 44"  
 Wt. 5.2 lbs.

**ACCESSORIES**

- Level base shoes
- Level base collars
- Angled base shoes
- Adjustable level base shoes
- Adjustable angle base shoes
- Level base collars(modern)
- Angled base collars(modern)
- Versatile style knuckle
- Newel mounting kit

- HF16.3.1, HF16.3.19, HF16.3.29**
- HF16.3.4, HF16.3.5,**
- HF16.3.2, HF16.3.30**
- HF16.3.44, HF16.3.46**
- HF16.3.45, HF16.3.47**
- HF16.3.9, HF16.3.60**
- HF16.3.61**
- HF16.5.1**
- HF16.2.3**

- Photos: A. A. C.
- Photos: D. H.
- Photos: E. G.
- Photos: R.
- Photos: S.
- Photos: P. O2 **NEW**
- Photos: O3 **NEW**
- Photos: F.
- Photos: T.

For photos and full accessory details see page 36



# RIBBON SQUARE



# Finishes & Patinas



SATIN BLACK  
(STB)



NEWEL

**HF 16.5.7**  
Ends : 1-3/16" Sq.  
Height: 48"  
Wt. 19 lbs.



**HF 16.1.5**  
Ends : 1/2" Sq.  
Height: 44"  
Wt. 3.2 lbs.



**HF 16.1.6**  
Ends : 1/2" Sq.  
Height: 44"  
Wt. 3 lbs.



**HF 16.3.6**  
Ends : 1/2" Sq.  
Height: 44"  
Wt. 3.2 lbs.



**HF 16.3.7**  
Ends : 1/2" Sq.  
Height: 44"  
Wt. 4 lbs.



**HF 16.1.10**  
 Ends : 1/2" Sq.  
 Height: 44"  
 Wt. 3.6 lbs.



**HF 16.1.11**  
 Ends : 1/2" Sq.  
 Height: 44"  
 Wt. 4.1 lbs.

**ACCESSORIES**

- Level base shoes
- Level base collars
- Angled base shoes
- Adjustable level base shoes
- Adjustable angle base shoes
- Level base collars(modern)
- Angled base collars(modern)
- Versatile style knuckle
- Newel mounting kit

- HF16.3.1, HF16.3.19, HF16.3.29**
- HF16.3.4, HF16.3.5,**
- HF16.3.2, HF16.3.30**
- HF16.3.44, HF16.3.46**
- HF16.3.45, HF16.3.47**
- HF16.3.9, HF16.3.60**
- HF16.3.61**
- HF16.5.1**
- HF16.2.3**

- Photos: A. A. C.
- Photos: D. H.
- Photos: E. G.
- Photos: R.
- Photos: S.
- Photos: P. O2 **NEW**
- Photos: O3 **NEW**
- Photos: F.
- Photos: T.

For photos and full accessory details see page 36



# TWIST SQUARE



## Finishes & Patinas



|     | NEWELS | HF16.5.4 | HF16.5.4-T | HF16.5.5 | HF16.5.5-T | BALUSTERS | HF16.1.1 | HF16.1.1-T | HF16.1.2 | HF16.1.2-T | HF16.1.3 | HF16.1.3-T | HF16.1.4 | HF16.1.4-T | HF16.1.21 | HF16.1.21-T | HF16.1.16 | HF16.1.41 |
|-----|--------|----------|------------|----------|------------|-----------|----------|------------|----------|------------|----------|------------|----------|------------|-----------|-------------|-----------|-----------|
| STB |        | •        |            | •        |            |           | •        | •          | •        | •          | •        | •          | •        | •          | •         | •           | •         | •         |
| AG  |        |          | •          |          | •          |           |          | •          |          | •          |          | •          |          | •          |           | •           |           |           |
| CV  |        |          |            |          |            |           | •        | •          | •        | •          | •        | •          | •        | •          | •         | •           |           |           |
| ORB |        |          |            |          |            |           | •        | •          | •        | •          | •        | •          | •        | •          | •         | •           |           |           |
| ORC |        |          |            |          |            |           | •        | •          | •        | •          | •        | •          | •        | •          | •         | •           |           |           |

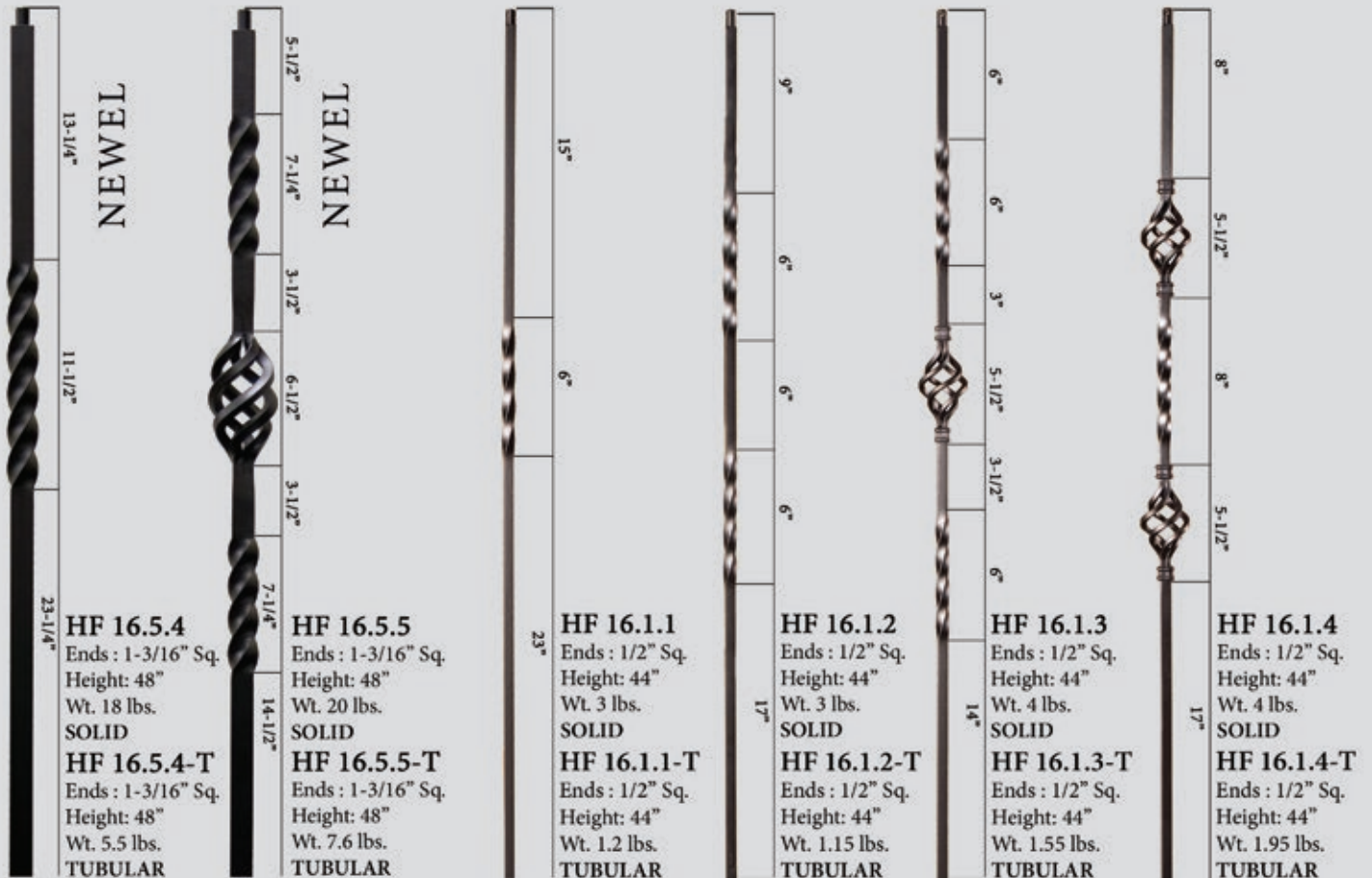

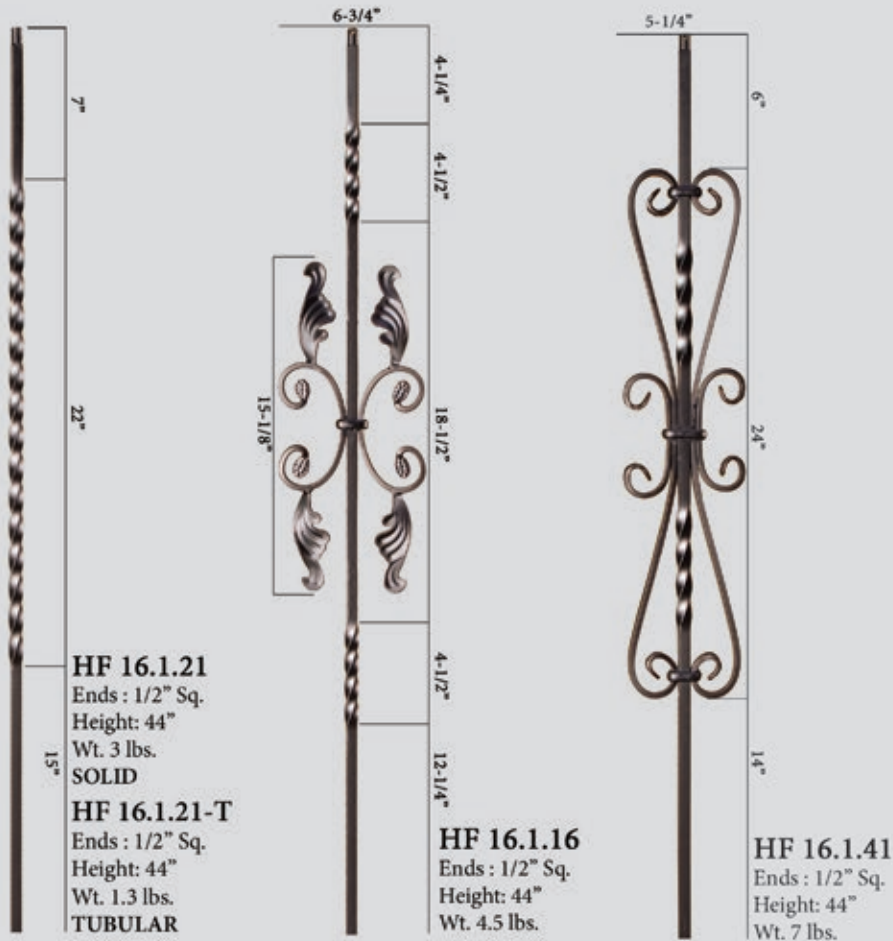

## ACCESSORIES

Level base shoes  
Level base collars  
Angled base shoes  
Adjustable level base shoes  
Adjustable angle base shoes  
Level base collars(modern)  
Angled base collars(modern)  
Versatile style knuckle  
Newel mounting kit

**HF16.3.1, HF16.3.19, HF16.3.29**  
**HF16.3.4, HF16.3.5,**  
**HF16.3.2, HF16.3.30**  
**HF16.3.44, HF16.3.46**  
**HF16.3.45, HF16.3.47**  
**HF16.3.9, HF16.3.60**  
**HF16.3.61**  
**HF16.5.1**  
**HF16.2.3**

Photos: A. A. C.  
Photos: D. H.  
Photos: E. G.  
Photos: R.  
Photos: S.  
Photos: P. O2 **NEW**  
Photos: O3 **NEW**  
Photos: F.  
Photos: T.

For photos and full accessory details see page 36



| Photo   | Part #     | Description  | ACCESSORY SPECIFICATIONS |  |  |   | STB | AG | CV | ORB | ORC | SC | GD |
|---|------------|--|--------------------------|--|--|---|-----|----|----|-----|-----|----|----|
| 1/2" Square Baluster Accessories  |            |  |                          |  |  |   |     |    |    |     |     |    |    |
| A.  | HF16.3.1   | Level base shoe, fits 1/2" square balusters, 1-5/16" square base, aluminum   |                          |  |  | • |     | •  |    | •   |     |    |    |
| A.  | HF16.3.19  | Level base shoe with set screw, fits 1/2" square balusters, 1-5/16" square base, aluminum  |                          |  |  | • | •   | •  | •  | •   |     | •  |    |
| E.  | HF16.3.2   | Angled base shoe with set screw, fits 1/2" square balusters, 1-5/16" base, aluminum  |                          |  |  | • | •   | •  | •  | •   |     | •  |    |
| B.  | HF16.3.21  | Level base shoe with screw mount, fits 1/2" square balusters, 1-9/16" square base, aluminum  |                          |  |  | • |     | •  |    |     |     |    |    |
| F.  | HF16.5.1   | Versatile style knuckle with set screw, fits 1/2" square balusters, 1-7/16" square, aluminum   |                          |  |  | • |     | •  | •  | •   |     |    |    |
| C.  | HF16.3.29  | Oil Rubbed Bronze, level base shoe with set screw, fits 1/2" square balusters, 1-1/4" square base, cast iron   |                          |  |  | • |     |    | •  |     |     |    |    |
| G.  | HF16.3.30  | Oil Rubbed Bronze, angled base shoe with set screw, fits 1/2" square balusters, 1-1/4" base, cast iron   |                          |  |  |   |     |    | •  |     |     |    |    |
| D.  | HF16.3.4   | Level base collar, fits 1/2" square balusters, 2" square base, aluminum  |                          |  |  | • |     | •  | •  | •   |     |    |    |
| H.  | HF16.3.5   | Level base collar, fits 1/2" square balusters, 1-15/16" round base, aluminum, (ORB - cast iron)  |                          |  |  | • |     | •  | •  | •   |     |    |    |
| P.  | HF16.3.9   | Level base collar, fits 1/2" square balusters, 1-9/16" round base, cast iron   |                          |  |  |   | •   | •  | •  |     |     | •  |    |
| O2.   | HF16.3.60  | Level base collar, fits 1/2" square balusters, 1-9/16" round base, aluminum  |                          |  |  | • |     |    |    |     |     |    |    |
| O3.   | HF16.3.61  | Angled base collar, fits 1/2" square balusters, 1-9/16" round base, aluminum   |                          |  |  | • |     |    |    |     |     |    |    |
| 9/16" Square Baluster Accessories   |            |  |                          |  |  |   |     |    |    |     |     |    |    |
| A.  | HF16.3.3   | Level base shoe, fits 9/16" square balusters, 1-5/16" square base, aluminum  |                          |  |  | • |     | •  |    | •   |     |    |    |
| A.  | HF16.3.20  | Level base shoe with set screw, fits 9/16" square balusters, 1-5/16" square base, aluminum   |                          |  |  | • |     |    | •  | •   |     |    |    |
| E.  | HF16.3.17  | Angled base shoe with set screw, fits 9/16" square balusters, 1-5/16" base, aluminum   |                          |  |  | • |     |    | •  | •   |     |    |    |
| C.  | HF16.3.25  | Level base shoe with set screw, fits 9/16" Tuscan square balusters, 1-1/4" square base, cast iron  |                          |  |  | • |     |    | •  |     | •   |    |    |
| G.  | HF16.3.28  | Angled base shoe with set screw, fits 9/16" Tuscan square balusters, 1-1/4" base, cast iron  |                          |  |  | • |     |    | •  |     |     |    |    |
| D.  | HF16.3.41  | Level base collar, fits 9/16" square balusters, 2" square base, cast iron  |                          |  |  |   |     |    | •  |     |     |    |    |
| H.  | HF16.3.42  | Level base collar, fits 9/16" square balusters, 1-15/16" round base, cast iron   |                          |  |  |   |     |    | •  |     |     |    |    |
| P.  | HF16.3.11  | Level base collar, fits 9/16" square balusters, 1-3/4" round base, cast iron   |                          |  |  |   |     |    | •  |     |     |    |    |
| 5/8" Square Baluster Accessories  |            |  |                          |  |  |   |     |    |    |     |     |    |    |
| C.  | HF16.3.38  | Level base shoe with set screw, fits 5/8" square balusters, 1-1/4" square base, cast iron  |                          |  |  | • |     |    | •  |     | •   |    |    |
| G.  | HF16.3.39  | Angled base shoe with set screw, fits 5/8" square balusters, 1-1/4" base, cast iron  |                          |  |  | • |     |    | •  |     | •   |    |    |
| P.  | HF16.3.15  | Level base collar, fits 5/8" square balusters, 1-3/4" round base, cast iron  |                          |  |  | • |     |    | •  |     |     |    |    |
| 3/4" Square Baluster Accessories  |            |  |                          |  |  |   |     |    |    |     |     |    |    |
| A.  | HF34.3.19  | Level base shoe with set screw, fits 3/4" square balusters, 1-7/8" square base, aluminum   |                          |  |  | • | •   |    | •  |     |     |    |    |
| E.  | HF34.3.2   | Level base shoe with set screw, fits 3/4" square balusters, 1-7/8" square base, aluminum   |                          |  |  | • | •   |    | •  |     |     |    |    |
| P.  | HF34.3.16  | Level base collar, fits 3/4" square balusters, 2" round base, cast iron  |                          |  |  | • | •   |    | •  |     |     |    |    |
| 9/16" Round Baluster Accessories  |            |  |                          |  |  |   |     |    |    |     |     |    |    |
| I.  | HF16.3.13  | Level base shoe, fits 9/16" round balusters, 1-5/16" square base, aluminum   |                          |  |  | • |     |    |    |     |     |    |    |
| M.  | HF16.3.16  | Angled base shoe with set screw, fits 9/16" round balusters, 1-5/16" base, aluminum  |                          |  |  | • |     |    |    |     |     |    |    |
| J.  | HF16.3.26  | Level base shoe with set screw, fits 9/16" round balusters, 1-1/4" square base, cast iron  |                          |  |  | • |     |    | •  |     | •   |    |    |
| N.  | HF16.3.27  | Angled base shoe with set screw, fits 9/16" round balusters, 1-1/4" base, cast iron  |                          |  |  | • |     |    | •  |     | •   |    |    |
| K.  | HF16.3.40  | Level base collar, fits 9/16" round balusters, 2" square base, cast iron   |                          |  |  |   |     |    | •  |     |     |    |    |
| O.  | HF16.3.43  | Level base collar, fits 9/16" round balusters, 1-15/16" round base, cast iron  |                          |  |  |   |     |    | •  |     |     |    |    |
| Q.  | HF16.3.10  | Level base collar, fits 9/16" round balusters, 1-9/16" round base, cast iron   |                          |  |  | • |     |    | •  |     |     |    |    |
| L.  | HF17.11.22 | Level base collar, fits 9/16" round stainless steel balusters, 1-1/2" round base, stainless steel  |                          |  |  |   |     |    |    |     |     |    |    |
| 5/8" Round Baluster Accessories   |            |  |                          |  |  |   |     |    |    |     |     |    |    |
| J.  | HF16.3.35  | Level base shoe with set screw, fits 5/8" round balusters, 1-1/4" square base, cast iron   |                          |  |  | • | •   |    | •  |     | •   |    |    |
| N.  | HF16.3.36  | Angled base shoe with set screw, fits 5/8" round balusters, 1-1/4" base, cast iron   |                          |  |  | • | •   |    | •  |     | •   |    |    |
| I.  | HF16.3.50  | Level base shoe with set screw, fits 5/8" round balusters, 1-5/16" square base, aluminum   |                          |  |  | • |     |    | •  |     |     |    |    |
| M.  | HF16.3.51  | Angled base shoe with set screw, fits 5/8" round balusters, 1-5/16" base, aluminum   |                          |  |  | • |     |    | •  |     |     |    |    |
| Q.  | HF16.3.12  | Level base collar, fits 5/8" round balusters, 1-9/16" round base, cast iron  |                          |  |  | • | •   |    | •  |     |     |    |    |
| Adjustable Shoes/Collars have a flexible insert that allows them to be used with either square or round balusters ranging in size from 1/2" to 9/16". Epoxy must be used to permanently secure. |            |  |                          |  |  |   |     |    |    |     |     |    |    |
| R.  | HF16.3.44  | Level base shoe, fits 1/2" - 9/16" square or round balusters, 1-5/16" square base, cast iron   |                          |  |  | • |     |    | •  |     | •   |    |    |
| R.  | HF16.3.46  | Level base shoe, fits 1/2" - 9/16" square or round balusters, 1-1/2" square base, cast iron  |                          |  |  | • |     |    | •  |     | •   |    |    |
| S.  | HF16.3.45  | Angled base shoe, fits 1/2" - 9/16" square or round balusters, 1-5/16" base, cast iron   |                          |  |  |   |     |    | •  |     | •   |    |    |
| S.  | HF16.3.47  | Angled base shoe, fits 1/2" - 9/16" square or round balusters, 1-1/2" base, cast iron  |                          |  |  |   |     |    | •  |     | •   |    |    |
| Newel Mounting Kits   |            |  |                          |  |  |   |     |    |    |     |     |    |    |
| T.  | HF16.2.3   | Newel mounting kit with level base shoe, fits 1-3/16" square newels, 3-1/8" square base, cast iron   |                          |  |  | • | •   |    | •  | •   |     | •  |    |
| T.  | HF16.3.31  | Newel mounting kit with level base shoe, fits 1" square newels, 3-1/8" square base, cast iron  |                          |  |  | • |     |    | •  |     | •   |    |    |
| U.  | HF16.3.14  | Newel mounting kit with level base shoe, fits 1-3/16" round newels, 3-1/8" square base, cast iron  |                          |  |  | • | •   |    | •  |     |     |    |    |
| U.  | HF16.3.33  | Newel mounting kit with level base shoe, fits 1" round newels, 3-1/8" square base, cast iron   |                          |  |  | • | •   |    | •  |     | •   |    |    |
| V.  | HF17.2.3   | Newel mounting kit with level base collar, fits 1-3/16" round stainless steel newels, 3-1/4" round base, stainless steel   |                          |  |  |   |     |    |    |     |     |    |    |
| V2.   | HF16.2.9   | Newel mounting kit, fits 1-3/16" round newels, flange cover sold separately. Flange covers: STB, AG, Stainless, Brass  |                          |  |  |   |     |    |    |     |     |    |    |
| Handrail Brackets   |            |  |                          |  |  |   |     |    |    |     |     |    |    |
| W.  | HF3002     | Handrail bracket, 1-1/4" x 2-3/8" mounting plate, extends out 3" from wall, aluminum<br>Also available in Brushed Chrome HFBC.3002, Polished Brass HFPB.3002                                   |                          |  |  | • | •   | •  | •  | •   | •   |    |    |
| X.  | HF3003     | Handrail bracket, 2-1/16" round mounting plate, extends out 3" from wall, aluminum<br>Also available in Chrome HFCE.3003, Brushed Chrome HFBC.3003, Nickel HFNL.3003, Polished Brass HFPB.3003 |                          |  |  | • | •   | •  | •  | •   | •   |    |    |

# ACCESSORY PROFILES

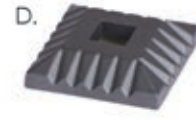

## Flange Covers

Use with HF16.2.9  
Newel Mounting Kit  
Fits 1-3/16" Round Newels  
Diameter: 4.13" Height: .7"

- SATIN BLACK HFSTB16.4.5
- ASH GREY HFAG16.4.5
- BRASS HF18.4.5
- STAINLESS STEEL HF17.4.5



- HFSTB-PEN  
Satin Black  
Touch-up Pen
- HFORB-PEN  
Oil Rubbed Bronze  
Touch-up Pen



30881 Beverly  
Romulus, MI 48174

Phone: (734) 729-0780  
Fax: (734) 729-0757

[www.jimmackiedistribution.com](http://www.jimmackiedistribution.com)

STAIR & RAILING PRODUCTS BY

